



(12) **United States Design Patent**
Chew et al.

(10) **Patent No.:** **US D963,540 S**
(45) **Date of Patent:** **** Sep. 13, 2022**

- (54) **BIB FOR A FUEL TANK INLET CONDUIT**
- (71) Applicant: **Marrk, llc**, Chesilhurst, NJ (US)
- (72) Inventors: **Michael Edward Chew**, Chesilhurst, NJ (US); **Russell Edward Chew**, Queens Village, NY (US)
- (73) Assignee: **Marrk. LLC**
- (**) Term: **15 Years**
- (21) Appl. No.: **29/749,910**
- (22) Filed: **Sep. 10, 2020**
- (51) **LOC (13) Cl.** **12-16**
- (52) **U.S. Cl.**
USPC **D12/190; D12/400**
- (58) **Field of Classification Search**
USPC D12/126, 181, 183, 184, 190, 197, 218, D12/400; D2/861, 862; D7/398, 624; D9/434, 457, 499; D20/22; D23/200, D23/207
CPC B60K 15/04; B60K 15/05
See application file for complete search history.

6,279,781 B1 *	8/2001	Konar	B67D 1/16
				222/108
7,216,778 B2 *	5/2007	Kaeb	B67D 1/16
				222/108
7,255,138 B2 *	8/2007	Coffman	B60K 15/05
				141/311 A
D650,040 S *	12/2011	Mirkovich	D23/200
8,162,168 B1 *	4/2012	Patulak	B60K 15/04
				220/731
D686,115 S *	7/2013	Saggau	D12/126
8,800,609 B1 *	8/2014	Krechowiecki	B60K 15/04
				141/338
9,187,309 B1 *	11/2015	Krechowiecki	B67D 7/04
D793,312 S *	8/2017	McNaughton	D12/400

* cited by examiner

Primary Examiner — Darlington Ly

(74) *Attorney, Agent, or Firm* — Ashok Tankha

(57) **CLAIM**

The ornamental design for a bib for a fuel tank inlet conduit, as shown and described.

DESCRIPTION

FIG. 1 is a front and left side perspective view of a bib for a fuel tank inlet conduit embodying our new design; FIG. 2 is a front elevation view thereof; FIG. 3 is a rear elevation view thereof; FIG. 4 is a left side perspective view thereof; FIG. 5 is a right side elevation view thereof; FIG. 6 is a top plan view thereof; FIG. 7 is a bottom plan view thereof; and, FIG. 8 is a front perspective view thereof, as installed on an exemplary fuel tank inlet conduit of a vehicle. The broken lines in the drawings illustrate portions of the bib for a fuel tank inlet conduit and environmental structure of a vehicle that form no part of the claimed design.

1 Claim, 6 Drawing Sheets

(56) **References Cited**

U.S. PATENT DOCUMENTS

2,659,523 A *	11/1953	Comber	B60J 11/10
				141/390
3,992,051 A	11/1976	Hitch	
D275,442 S *	9/1984	Hayes	D8/18
4,817,691 A *	4/1989	Lau	B67D 7/421
				141/390
D315,705 S *	3/1991	Smith	D12/400
5,571,249 A *	11/1996	Boylen	B60K 15/04
				141/311 A
D387,723 S *	12/1997	Holmes	D12/190
5,785,099 A *	7/1998	Kashani	B60K 15/04
				141/86
D425,842 S *	5/2000	McNaughton	D12/181





FIG. 1

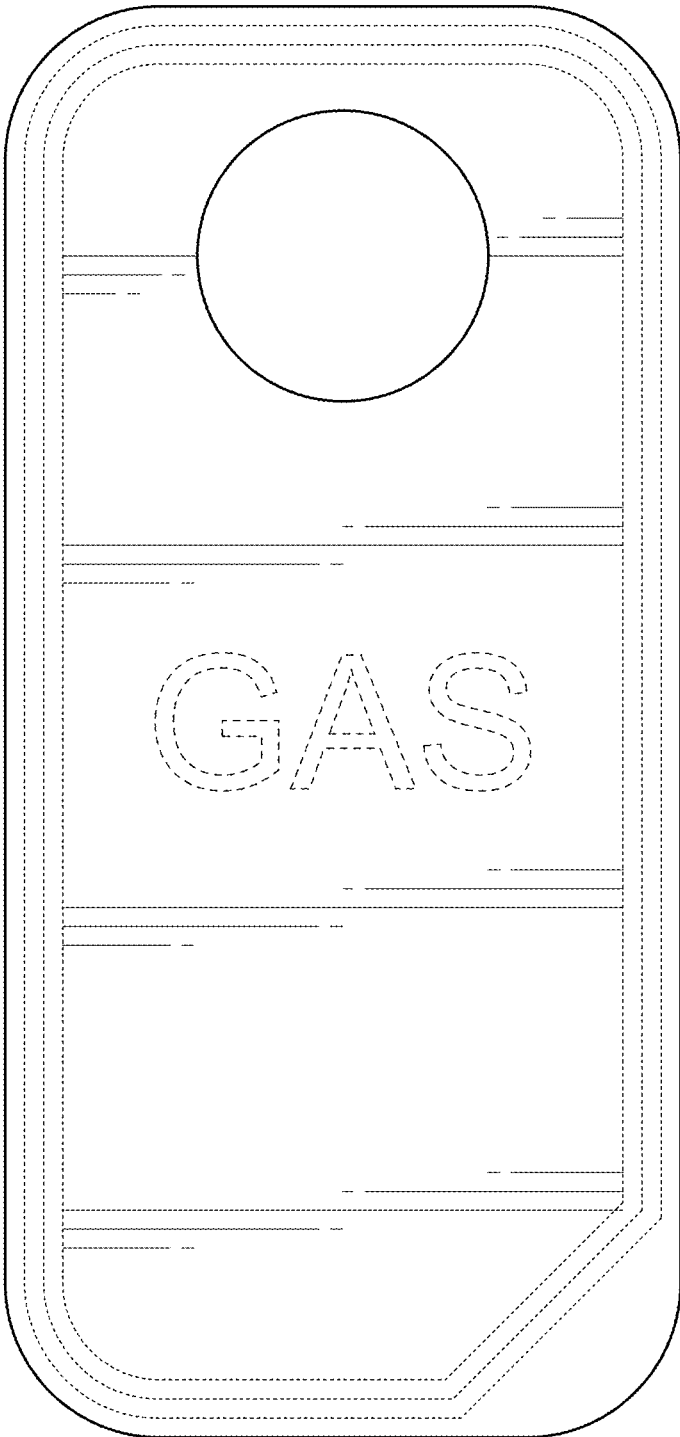

FIG. 2

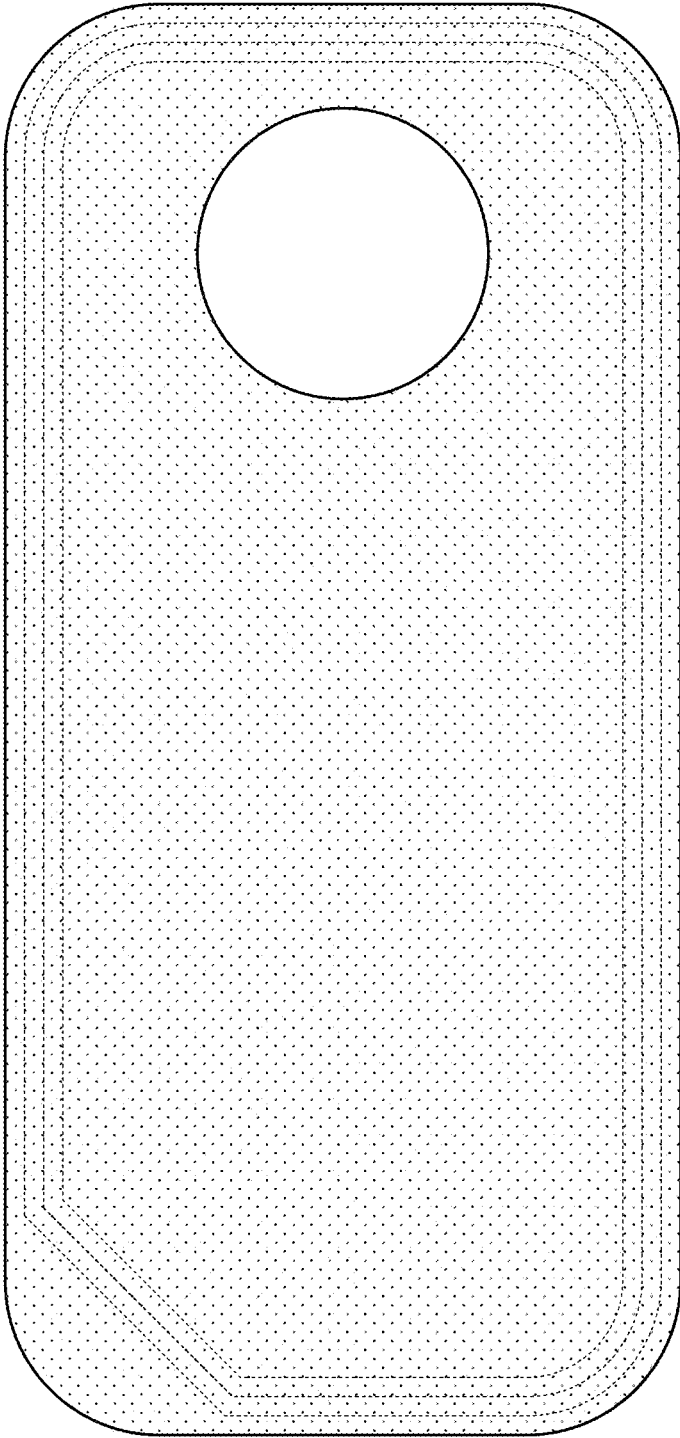

FIG. 3



FIG. 4



FIG. 5



FIG. 6

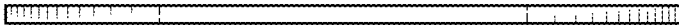

FIG. 7

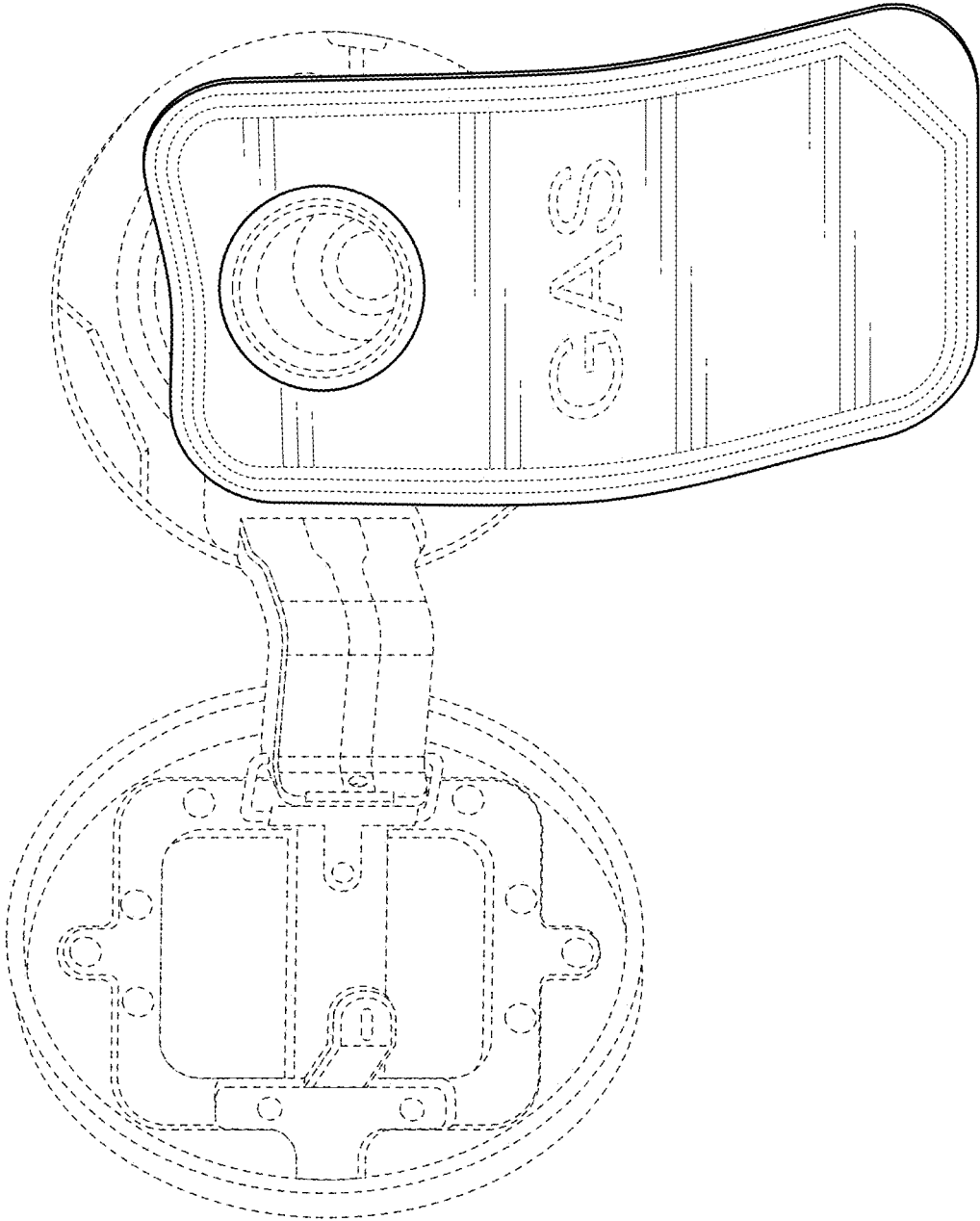

FIG. 8