



(19) **United States**

(12) **Patent Application Publication**  
**Gilles, JR.**

(10) **Pub. No.: US 2016/0114847 A1**  
(43) **Pub. Date: Apr. 28, 2016**

(54) **SADDLEBAG SUPPORT APPARATUS**

(52) **U.S. Cl.**

(71) Applicant: **Douglas James Gilles, JR.**, Manhattan, KS (US)

CPC ... **B62J 7/04** (2013.01); **B62J 9/001** (2013.01)

(72) Inventor: **Douglas James Gilles, JR.**, Manhattan, KS (US)

(57) **ABSTRACT**

(21) Appl. No.: **14/924,726**

A saddlebag support apparatus includes at least two arms and a support frame with a geometric shape. The arms are removably connected, for example, to a rear section of a vehicle, for example, a motorcycle. The support frame extends from lower ends of the arms. The support frame defines a receptacle for receiving one or more attachment elements of a saddlebag to secure the saddlebag to the support frame. The saddlebag support apparatus includes an interconnecting member positioned and connected between the two arms for precluding deflection of the support frame when the saddlebag is mounted onto the support frame, thereby providing rigidity to the support frame. The saddlebag support apparatus includes one or more connector elements positioned at predetermined locations on an inner plane of the support frame for receiving and accommodating one or more attachment elements of the saddlebag to secure the saddlebag to the support frame.

(22) Filed: **Oct. 28, 2015**

**Related U.S. Application Data**

(60) Provisional application No. 62/069,818, filed on Oct. 28, 2014.

**Publication Classification**

(51) **Int. Cl.**  
**B62J 7/04** (2006.01)  
**B62J 9/00** (2006.01)

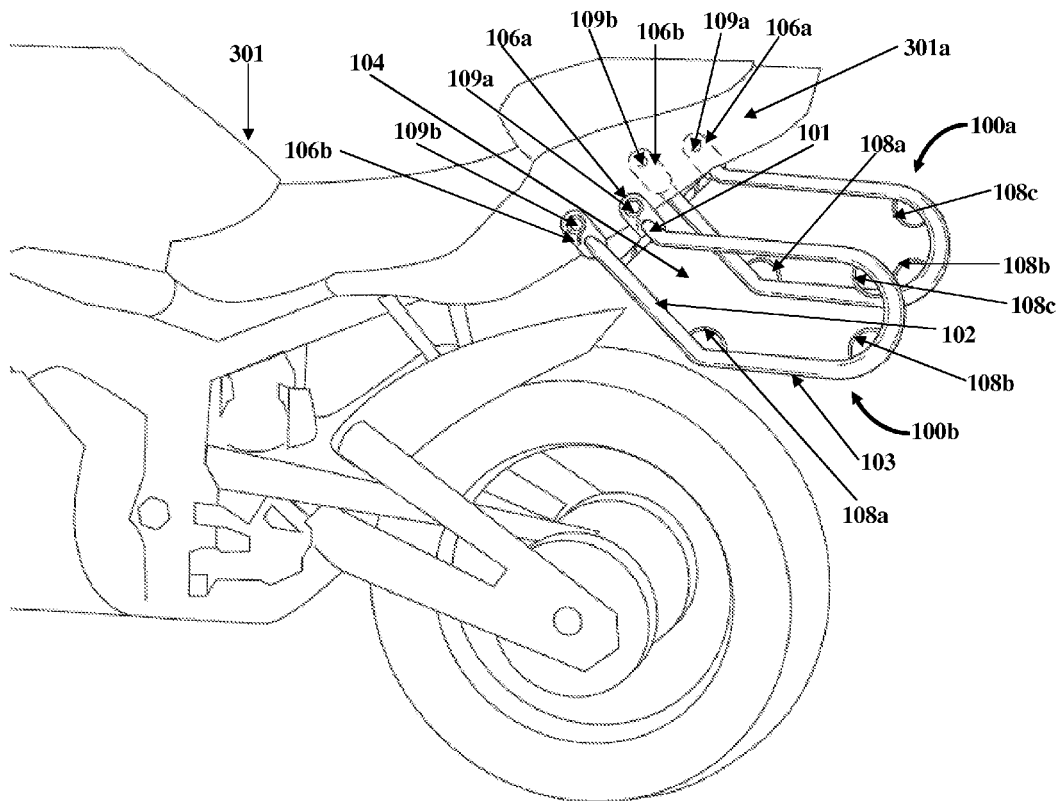

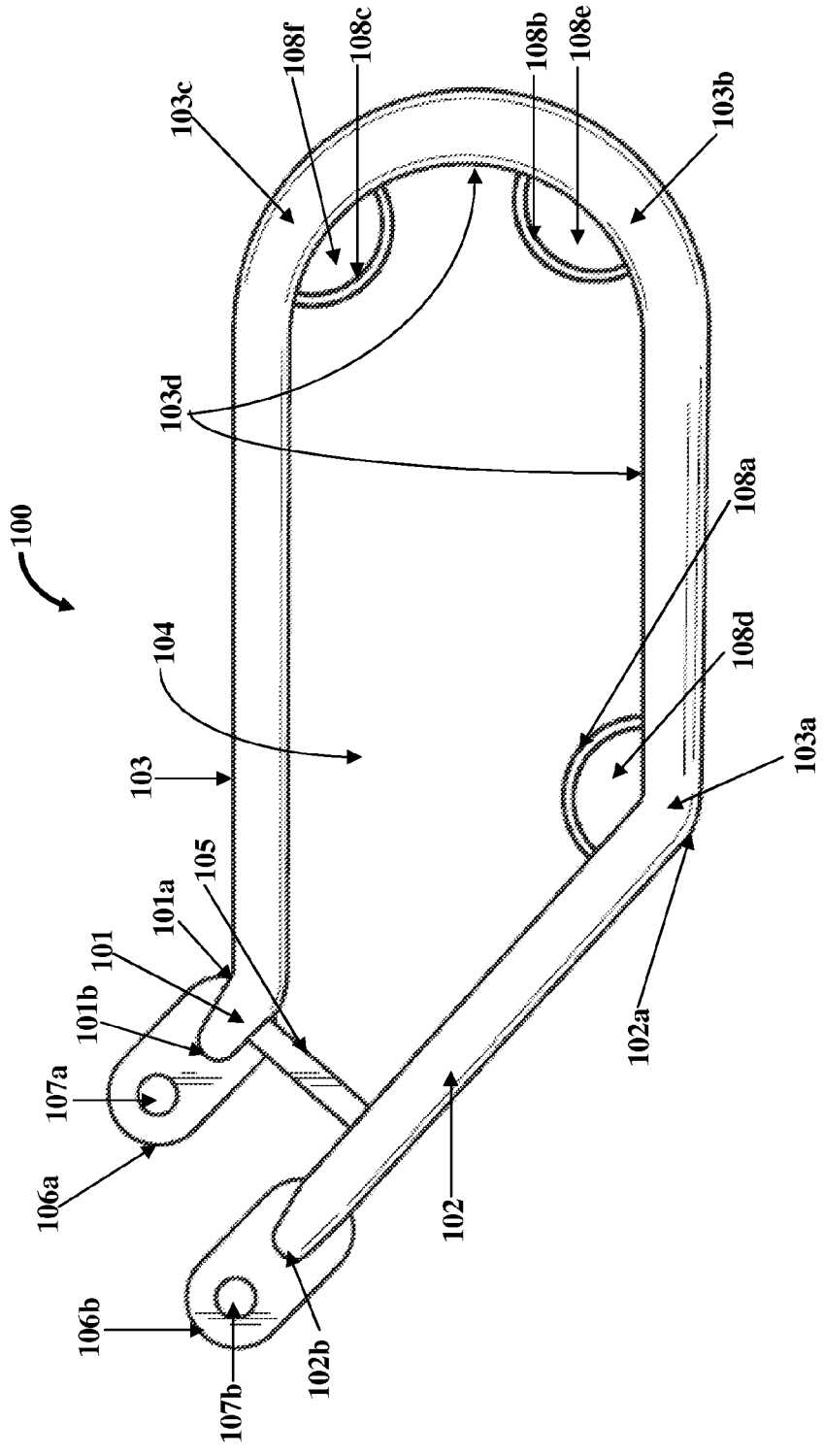

FIG. 1A

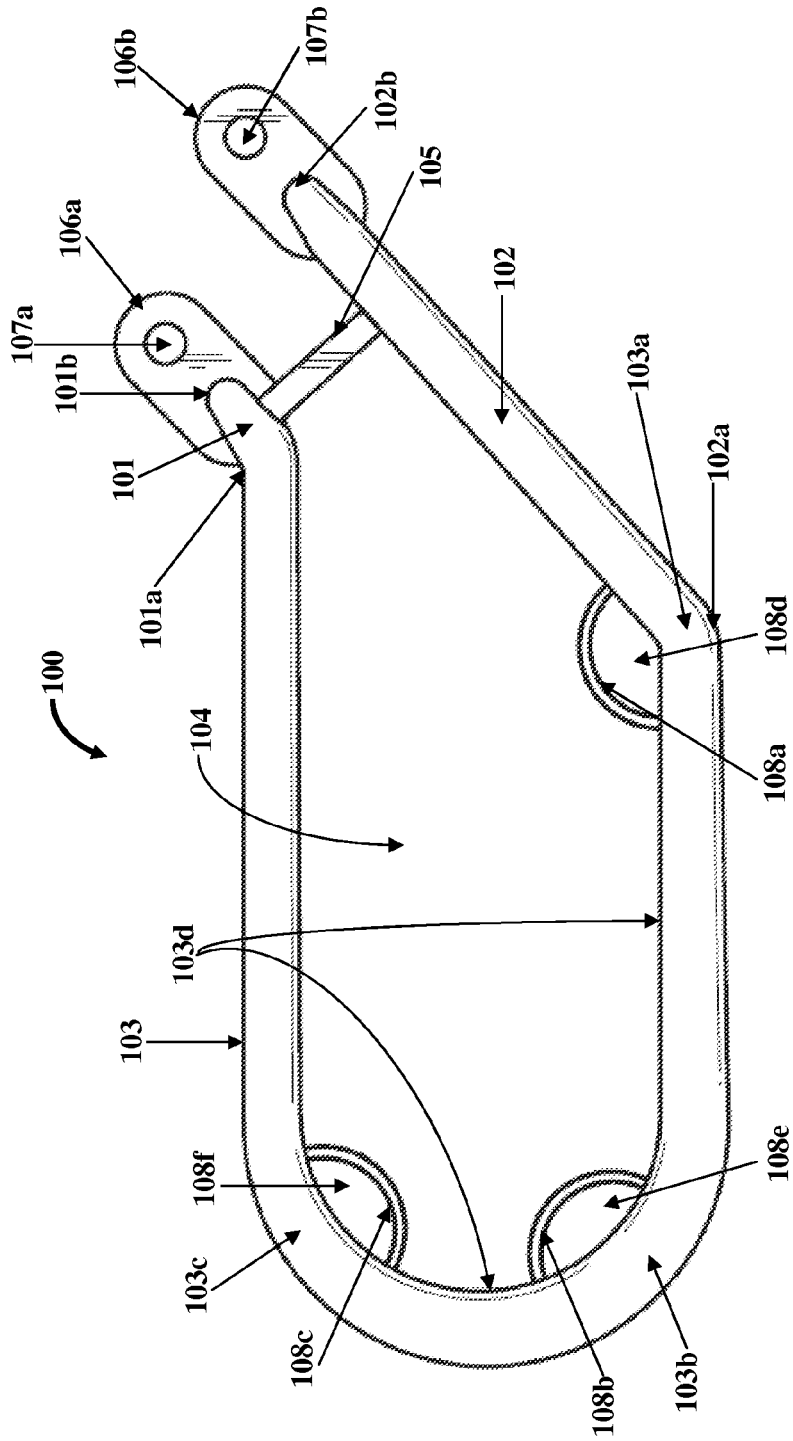

FIG. 1B

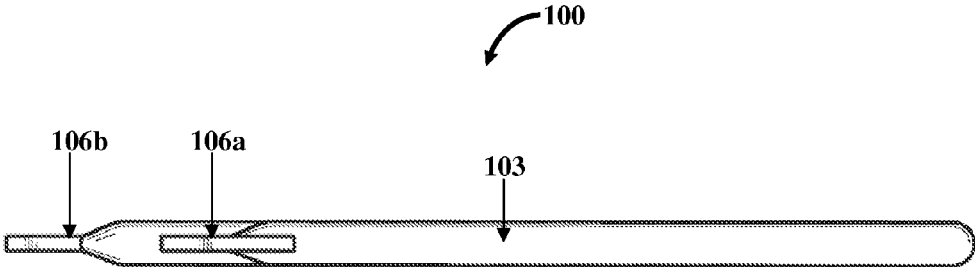

FIG. 1C

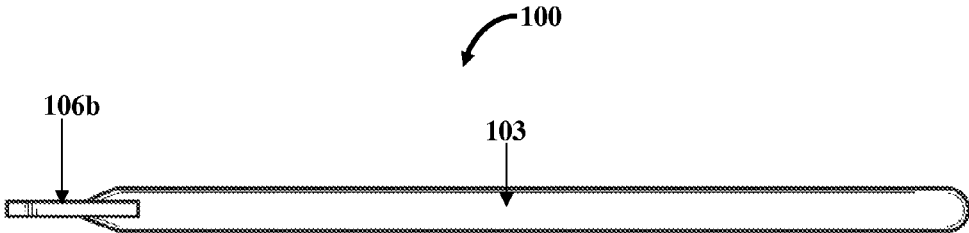

FIG. 1D

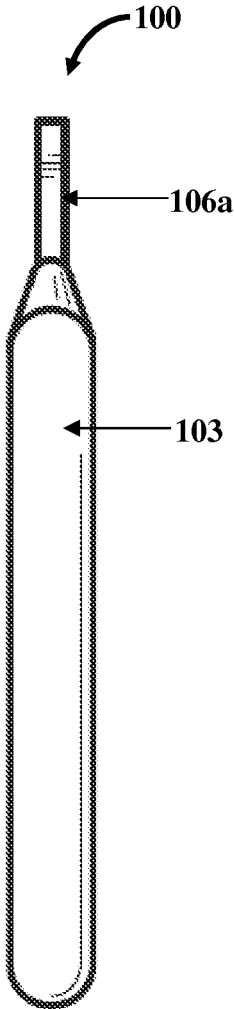

FIG. 1E

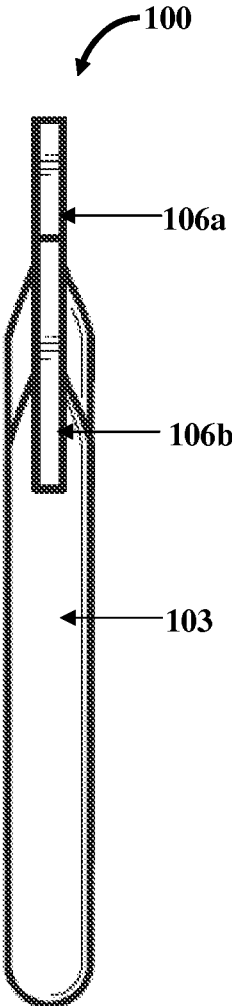

FIG. 1F

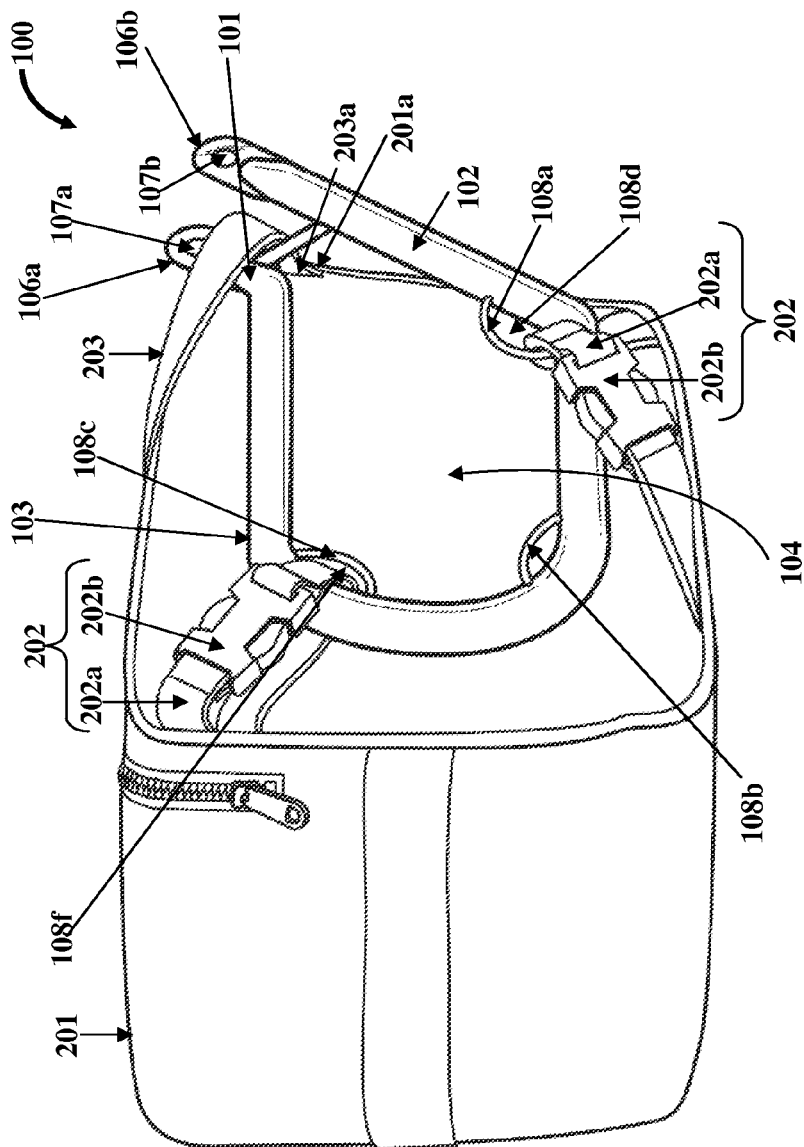

FIG. 2A

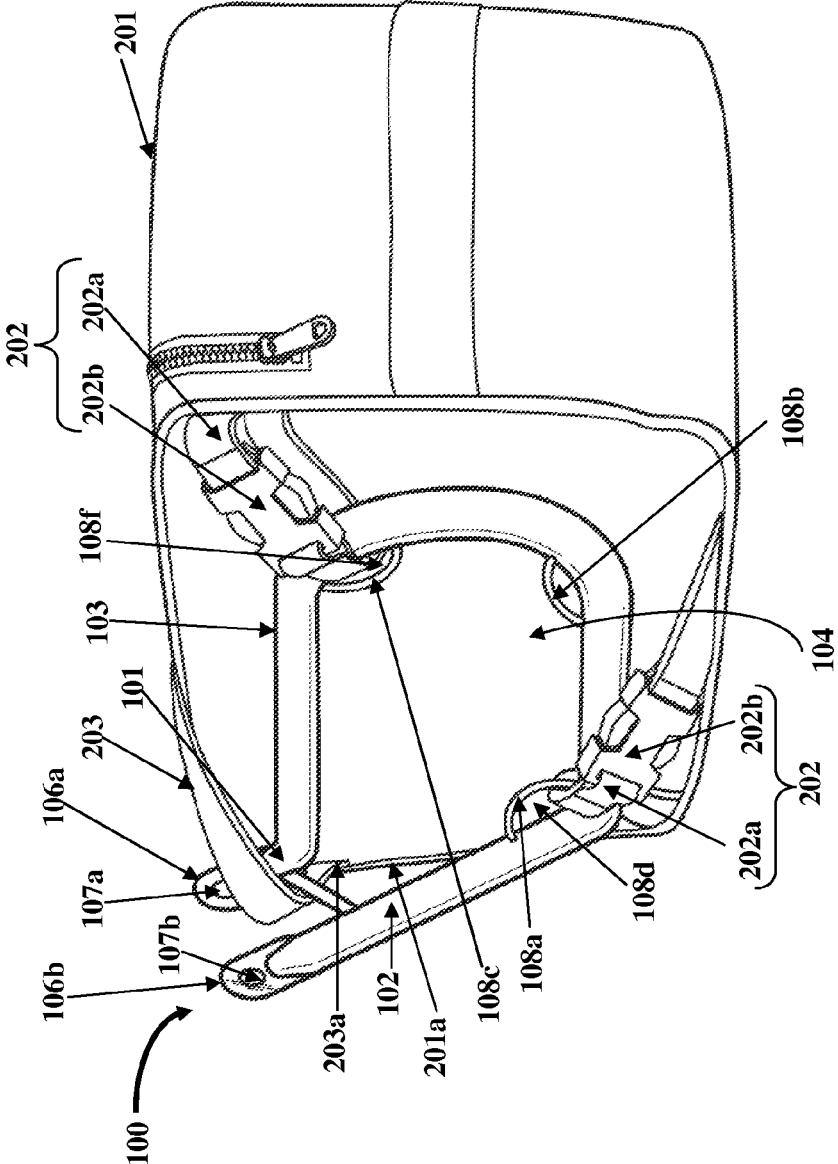

FIG. 2B



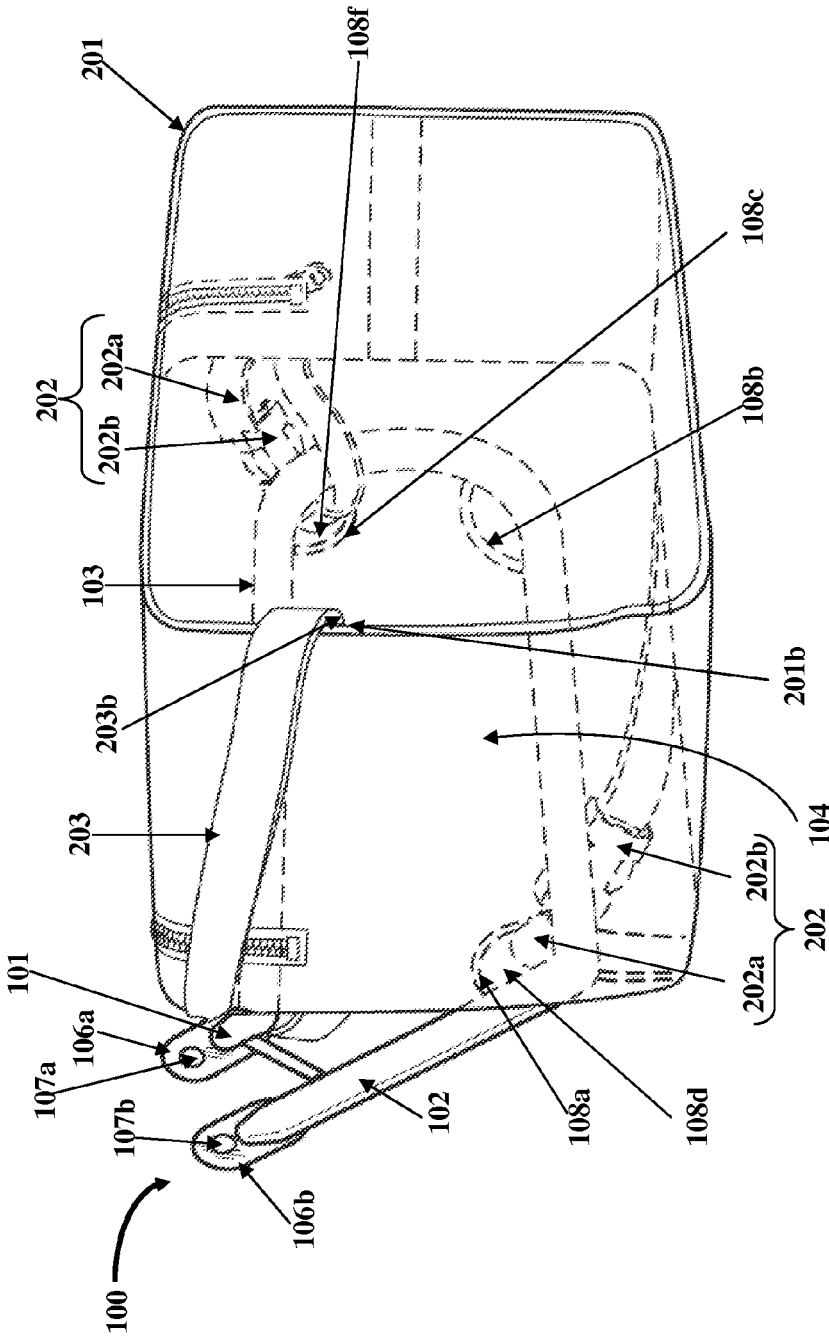

FIG. 2C



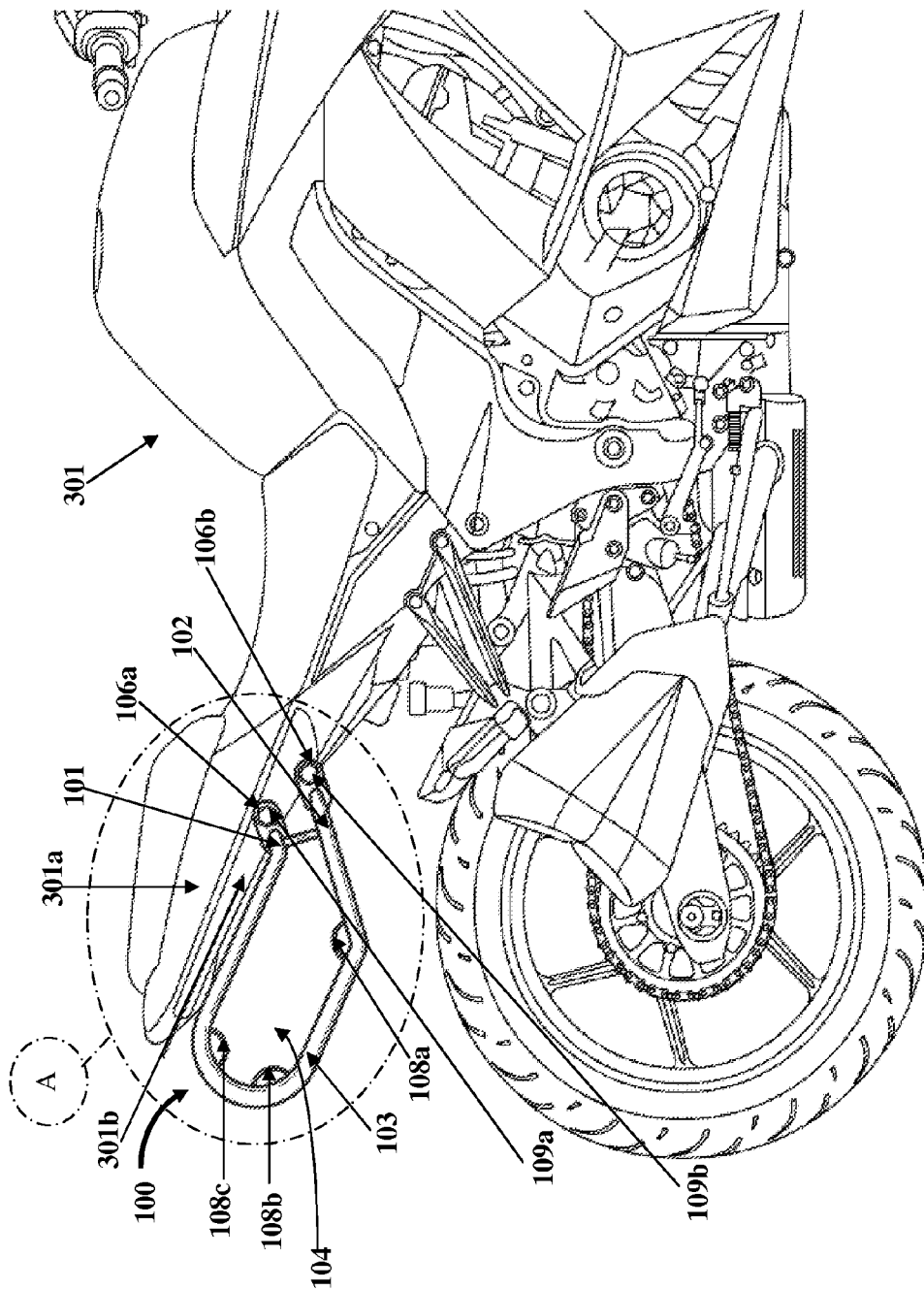

FIG. 4A

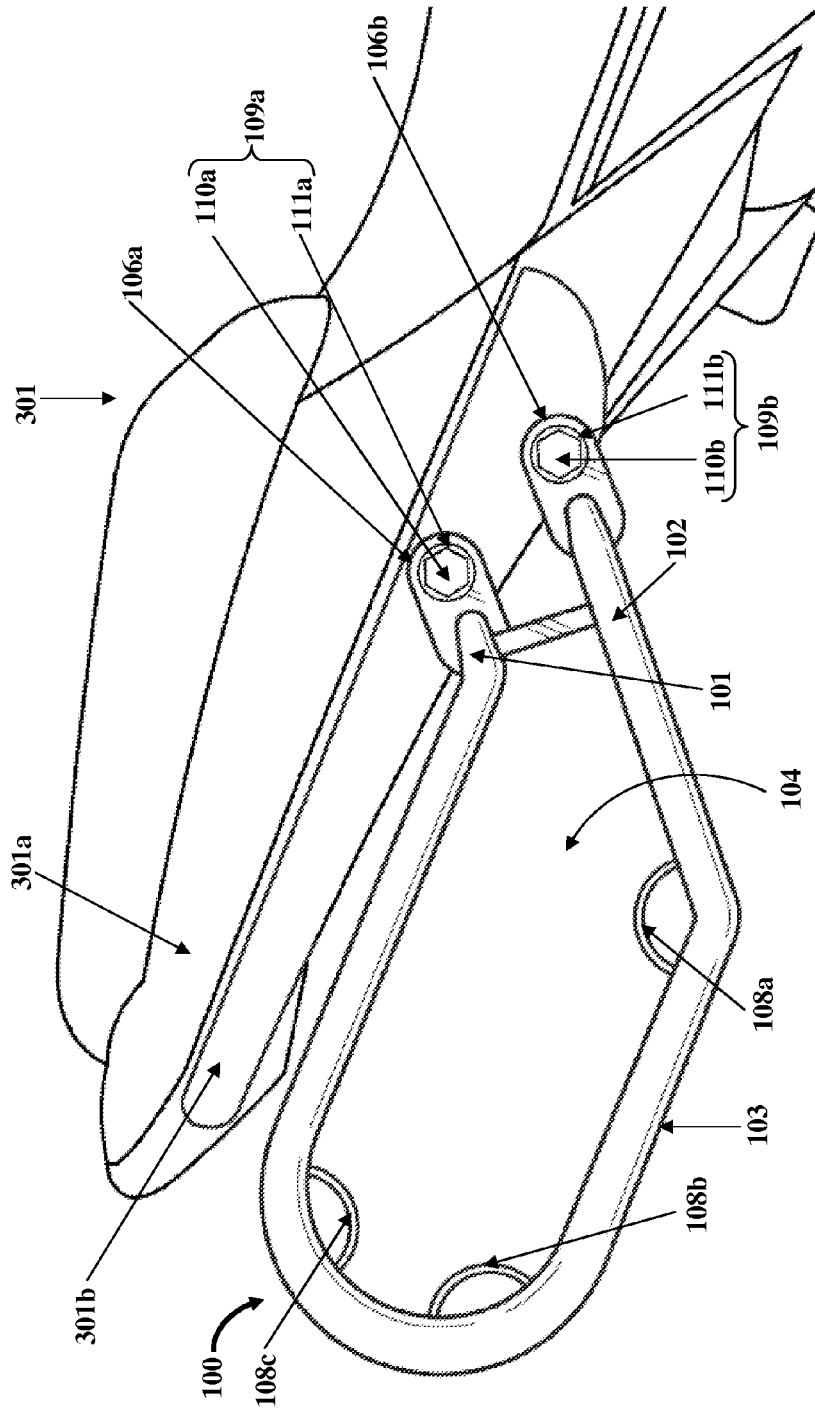
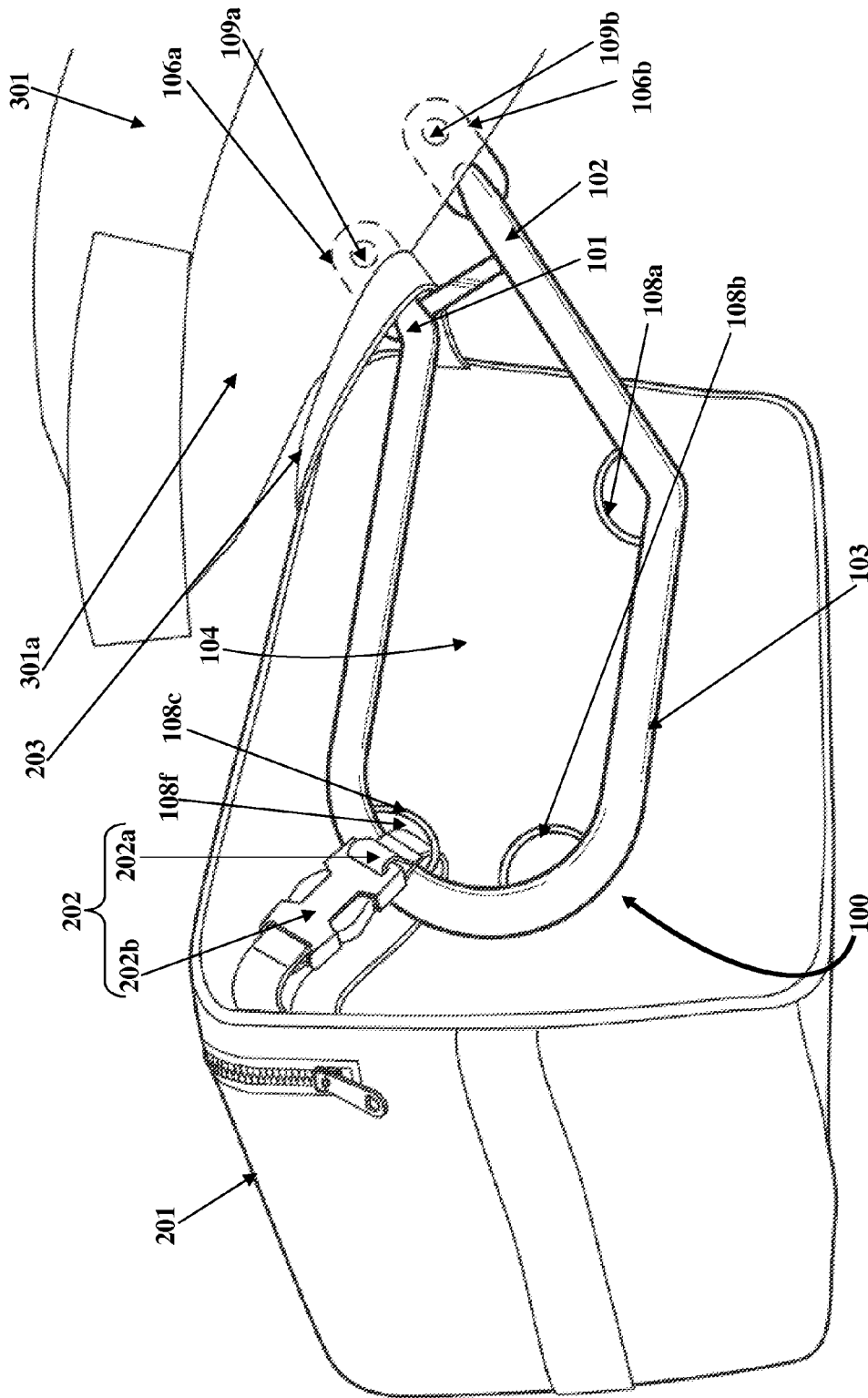

FIG. 4B



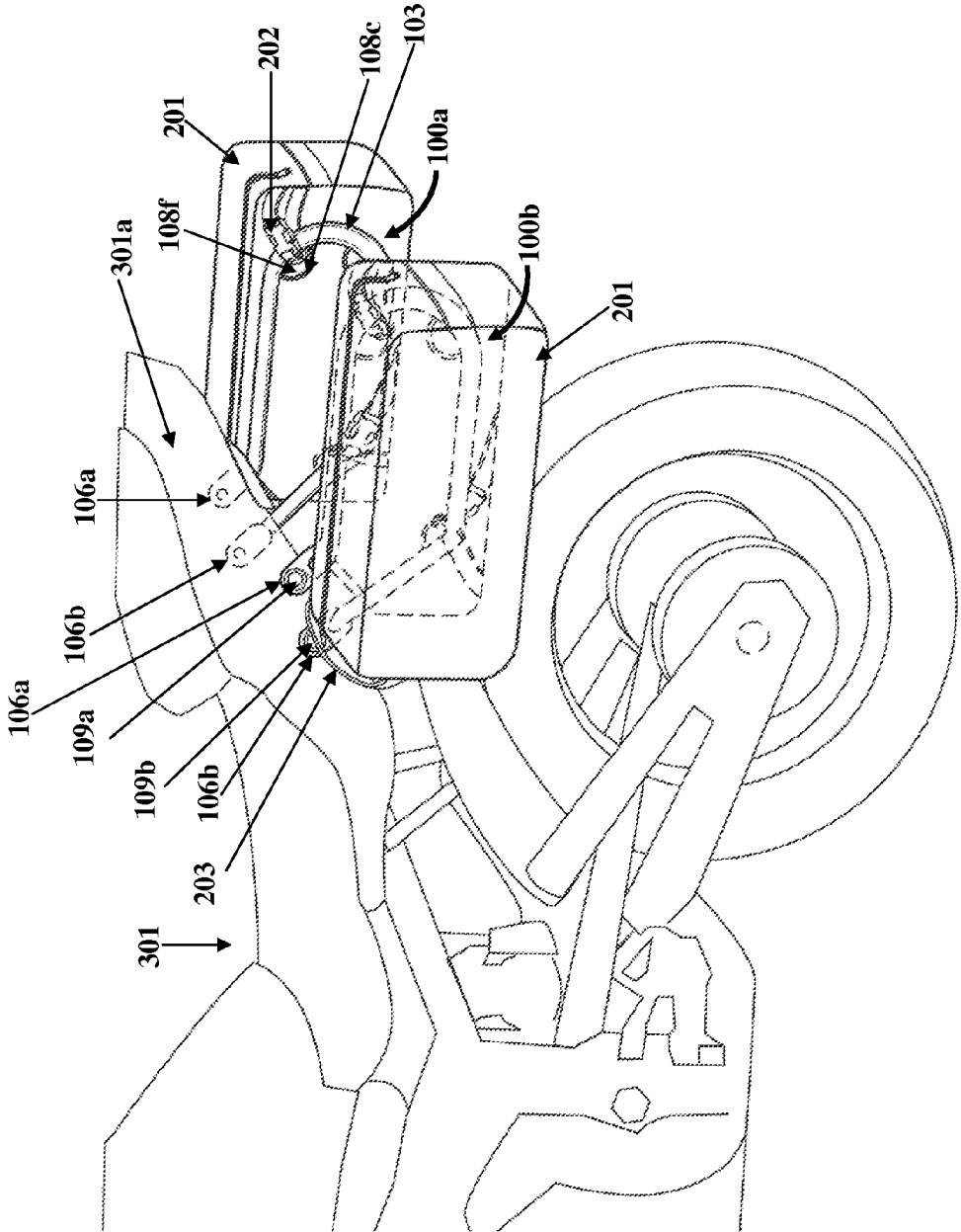

FIG. 6A



## SADDLEBAG SUPPORT APPARATUS

### CROSS-REFERENCE TO RELATED APPLICATIONS

[0001] This application claims priority to and the benefit of provisional patent application No. 62/069,818 titled "Saddlebag Support Apparatus", filed in the United States Patent and Trademark Office on Oct. 28, 2014. The specification of the above referenced patent application is incorporated herein by reference in its entirety.

### BACKGROUND

[0002] Motorcycling is a means of transportation and also a leisure time activity for many users. For activities such as transportation and leisure, a motorcycle typically lacks cargo carrying capabilities. Many motorcycle owners use saddlebags mounted to the rear of the motorcycle to address the cargo carrying deficiency. While substantially rigid, non-flexible saddlebags are typically incorporated on the rear of the motorcycle, many motorcycle owners prefer the flexibility of aftermarket flexible saddlebags. However, flexible saddlebags are typically difficult to mount on the rear of the motorcycle because they interfere with passenger hand grips, mufflers, fenders, etc., and are difficult to install and secure in place. Therefore, there is a need for an apparatus by which flexible saddlebags can be easily mounted to a motorcycle without affecting other systems and components of the motorcycle.

[0003] Hence, there is a long felt but unresolved need for a saddlebag support apparatus for removably attaching one or more flexible saddlebags to a vehicle, for example, a motorcycle, for carrying items or cargo on the vehicle.

### SUMMARY OF THE INVENTION

[0004] This summary is provided to introduce a selection of concepts in a simplified form that are further disclosed in the detailed description of the invention. This summary is not intended to identify key or essential inventive concepts of the claimed subject matter, nor is it intended to determine the scope of the claimed subject matter.

[0005] The saddlebag support apparatus disclosed herein addresses the above stated need for an apparatus that removably attaches one or more saddlebags to a vehicle, for example, a motorcycle, for carrying items or cargo on the vehicle, without affecting other systems and components of the vehicle. The saddlebag support apparatus disclosed herein comprises at least two arms and a support frame with a geometric shape. The arms are removably connected to a rear section of the vehicle. The support frame extends from the lower ends of the arms. The support frame defines a receptacle for receiving one or more attachment elements, for example, straps of a saddlebag to secure the saddlebag to the support frame. In an embodiment, the saddlebag support apparatus disclosed herein further comprises one or more connector elements positioned at predetermined locations on an inner plane of the support frame. The connector elements comprise openings for receiving and accommodating one or more attachment elements of the saddlebag to secure the saddlebag to the support frame.

[0006] Disclosed herein is also a kit comprising the saddlebag support apparatus as disclosed above and a saddlebag detachably attached to the saddlebag support apparatus for carrying items on the vehicle. The saddlebag comprises one

or more attachment elements configured to be inserted into the openings of the connector elements of the saddlebag support apparatus and secured to the support frame of the saddlebag support apparatus.

### BRIEF DESCRIPTION OF THE DRAWINGS

[0007] The foregoing summary, as well as the following detailed description of the invention, is better understood when read in conjunction with the appended drawings. For the purpose of illustrating the invention, exemplary constructions of the invention are shown in the drawings. However, the invention is not limited to the specific methods and structures disclosed herein. The description of a method step or a structure referenced by a numeral in a drawing is applicable to the description of that method step or structure shown by that same numeral in any subsequent drawing herein.

[0008] FIGS. 1A-1F exemplarily illustrate different elevation views of a saddlebag support apparatus.

[0009] FIG. 2A exemplarily illustrates a rear perspective view of the saddlebag support apparatus, showing a saddlebag secured to the saddlebag support apparatus.

[0010] FIG. 2B exemplarily illustrates a front perspective view of the saddlebag support apparatus, showing a saddlebag secured to the saddlebag support apparatus.

[0011] FIG. 2C exemplarily illustrates a perspective view of the saddlebag support apparatus, showing a saddlebag secured to the saddlebag support apparatus.

[0012] FIG. 3 exemplarily illustrates a rear perspective view of a vehicle, showing a pair of saddlebag support apparatuses attached to a rear section of the vehicle.

[0013] FIG. 4A exemplarily illustrates a right side elevation view of a vehicle, showing a single saddlebag support apparatus attached to a rear section of the vehicle using fastening attachments.

[0014] FIG. 4B exemplarily illustrates an enlarged view of a portion marked A in FIG. 4A.

[0015] FIG. 5 exemplarily illustrates an enlarged view of the saddlebag support apparatus, showing a saddlebag secured to the saddlebag support apparatus.

[0016] FIG. 6A exemplarily illustrates a left side perspective view of a vehicle, showing a pair of saddlebag support apparatuses attached to a rear section of the vehicle and saddlebags secured to the saddlebag support apparatuses.

[0017] FIG. 6B exemplarily illustrates a rear elevation view of a vehicle, showing a pair of saddlebag support apparatuses attached to a rear section of the vehicle and saddlebags secured to the saddlebag support apparatuses.

### DETAILED DESCRIPTION OF THE INVENTION

[0018] FIGS. 1A-1F exemplarily illustrate different elevation views of a saddlebag support apparatus 100. As used herein, the term "saddlebag" refers to a storage bag used for storage of items or cargo and that is removably attached to a saddle of a vehicle 301 exemplarily illustrated in FIG. 5 and FIGS. 6A-6B. In an embodiment, the vehicle 301 is a two wheeled vehicle, for example, a bicycle, a motorcycle, etc. The saddlebag support apparatus 100 disclosed herein is made of, for example, tube steel or solid round steel with a diameter of, for example, about 3/4 inches. FIG. 1A and FIG. 1B exemplarily illustrate a front elevation view and a rear elevation view of the saddlebag support apparatus 100 respectively. FIG. 1C and FIG. 1D exemplarily illustrate a top plan view and a bottom elevation view of the saddlebag sup-



port apparatus 100 respectively. FIG. 1E and FIG. 1F exemplarily illustrate a right side elevation view and a left side elevation view of the saddlebag support apparatus 100 respectively.

[0019] The saddlebag support apparatus 100 disclosed herein comprises at least two arms 101 and 102 and a support frame 103. The arms 101 and 102 are removably connected to a rear section 301a of a vehicle 301 as exemplarily illustrated in FIG. 3. As exemplarily illustrated in FIGS. 1A-1B, the arm 102 is substantially longer than the arm 101. The support frame 103 is configured as a bracket with a geometric shape, for example, a partially oval shape. In an embodiment, the support frame 103 is a generally rectangular frame with generally curved corners. The support frame 103 extends from lower ends 101a and 102a of the arms 101 and 102 respectively. The support frame 103 defines a receptacle 104 for receiving one or more attachment elements 202 of a saddlebag 201 to secure the saddlebag 201 to the support frame 103 as exemplarily illustrated in FIGS. 2A-2C, FIG. 5, and FIGS. 6A-6B.

[0020] In an embodiment, the saddlebag support apparatus 100 disclosed herein further comprises an interconnecting member 105 positioned and connected between the arms 101 and 102 and substantially perpendicular to each of the arms 101 and 102. The interconnecting member 105 precludes deflection of the support frame 103 when the saddlebag 201 is mounted onto the support frame 103, thereby providing rigidity to the support frame 103. In an embodiment, the interconnecting member 105 is a solid stiffening member welded between the arms 101 and 102. In an embodiment, the saddlebag support apparatus 100 disclosed herein further comprises mounting brackets 106a and 106b as exemplarily illustrated in FIGS. 1A-1B, rigidly attached to upper ends 101b and 102b of the arms 101 and 102 respectively. The mounting brackets 106a and 106b comprises through holes 107a and 107b respectively, exemplarily illustrated in FIGS. 1A-1B, for receiving fastening attachments 109a and 109b exemplarily illustrated in FIG. 3 and FIGS. 4A-4B, that fasten the saddlebag support apparatus 100 to the rear section 301a of the vehicle 301.

[0021] In an embodiment as exemplarily illustrated in FIGS. 1A-1B, the saddlebag support apparatus 100 disclosed herein further comprises one or more connector elements 108a, 108b, and 108c positioned at predetermined locations on an inner plane 103d of the support frame 103. In an embodiment, one connector element 108a is positioned at a bend 103a defined between the lower end 102a of one arm 102 of the saddlebag support apparatus 100 and the support frame 103, while the two connector elements 108b and 108c are connected to curved sections 103b and 103c of the support frame 103 respectively. In an embodiment, the connector elements 108a, 108b, and 108c are of a geometric shape, for example, a semicircular shape. The connector elements 108a, 108b, and 108c comprise openings 108d, 108e, and 108f respectively, for receiving and accommodating one or more attachment elements 202 of the saddlebag 201 exemplarily illustrated in FIGS. 2A-2C, FIG. 5, and FIGS. 6A-6B, to secure the saddlebag 201 to the support frame 103.

[0022] In an embodiment, the arms 101 and 102 and the support frame 103 of the saddlebag support apparatus 100 are made of, for example, about 1/2 inch or 3/8 inch diameter tube steel or tube stock that is machine bent. The height of the support frame 103 is, for example, about 5.5 inches to about 6.5 inches, and the width of the support frame 103 is, for

example, about 10 inches to about 11 inches. The height of the receptacle 104 of the support frame 103 is, for example, about 4.5 inches to about 5.5 inches and the width of the receptacle 104 of the support frame 103 is, for example, about 9 inches to about 10 inches. The length of the interconnecting member 105 is, for example, about 2 inches.

[0023] FIGS. 2A-2B exemplarily illustrate a rear perspective view and a front perspective view of the saddlebag support apparatus 100, showing a saddlebag 201 secured to the saddlebag support apparatus 100. The saddlebag 201 comprises one or more attachment elements 202 for securing the saddlebag 201 to the support frame 103 of the saddlebag support apparatus 100. The attachment elements 202 of the saddlebag 201 comprise, for example, straps 202a made of, for example, fabric, leather, etc., used for suspending the saddlebag 201, and fasteners 202b, for example, snap fit fasteners such as buckle fasteners for fastening the straps 202a of the saddlebag 201 to the saddlebag support apparatus 100. The attachment elements 202 of the saddlebag 201 can be attached to any one or more of the connector elements 108a, 108b, and 108c of the saddlebag support apparatus 100. For example, two straps 202a of the saddlebag 201 are inserted into the openings 108d and 108f of two connector elements 108a and 108c respectively, and fastened using the fasteners 202b as exemplarily illustrated in FIGS. 2A-2B, to secure the saddlebag 201 to the saddlebag support apparatus 100. In an embodiment, another strap 203 of the saddlebag 201 can be connected to the arm 101 of the saddlebag support apparatus 100. One end 203a of the strap 203 is sewn into a side 201a of the saddlebag 201. The strap 203 extends from the side 201a of the saddlebag 201, over the top of the saddlebag 201 to the other side 201b of the saddlebag 201 exemplarily illustrated in FIG. 2C. In an embodiment, the strap 203 is made of a flexible material, for example, leather, of width, for example, about 1 inch.

[0024] FIG. 2C exemplarily illustrates a perspective view of the saddlebag support apparatus 100, showing a saddlebag 201 secured to the saddlebag support apparatus 100. In addition to the attachment elements 202 comprising the straps 202a and the fasteners 202b, the saddlebag 201 further comprises the strap 203 connected to opposing sides 201a and 201b of the saddlebag 201 as exemplarily illustrated in FIGS. 2A-2C. One end 203a of the strap 203 is sewn into one side 201a of the saddlebag 201 exemplarily illustrated in FIGS. 2A-2B, and the other end 203b of the strap 203 is sewn into the other side 201b of the saddlebag 201 as exemplarily illustrated in FIG. 2C. In an embodiment, the strap 203 extends from the sides 201a and 201b of the saddlebag 201 and loops around the arm 101 of the saddlebag support apparatus 100 to hold the saddlebag 201 to the support frame 103 of the saddlebag support apparatus 100. In another embodiment, the strap 203 can be wound through any one or more of the connector elements 108a, 108b, and 108c of the saddlebag support apparatus 100 to secure the saddlebag 201 to the support frame 103 of the saddlebag support apparatus 100. In an embodiment, when the saddlebag 201 is detached from the saddlebag support apparatus 100, the strap 203 of the saddlebag 201 allows a user to pick up and carry the saddlebag 201.

[0025] FIG. 3 exemplarily illustrates a rear perspective view of a vehicle 301, showing a pair of saddlebag support apparatuses 100a and 100b attached to a rear section 301a of the vehicle 301. The pair of saddlebag support apparatuses 100a and 100b is, for example, a pair of flexible saddlebag brackets configured as aftermarket mounting brackets to be

attached to a vehicle 301, for example, a motorcycle to hold different types of aftermarket flexible saddlebags 201 exemplarily illustrated in FIGS. 6A-6B. The rear section 301a of the motorcycle is referred to as a rear cowl. The pair of saddlebag support apparatuses 100a and 100b is fastened to the rear cowl of the motorcycle. In an embodiment, the pair of saddlebag support apparatuses 100a and 100b is attached to the rear cowl by drilling holes through the rear cowl, positioning the through holes 107a and 107b of the mounting brackets 106a and 106b respectively, of the saddlebag support apparatuses 100a and 100b coaxial with the drilled holes on the rear cowl, and fastening the saddlebag support apparatuses 100a and 100b to the rear cowl by using the fastening attachments 109a and 109b.

[0026] FIG. 4A exemplarily illustrates a right side elevation view of a vehicle 301, showing a single saddlebag support apparatus 100 attached to a rear section 301a of the vehicle 301 using the fastening attachments 109a and 109b. FIG. 4B exemplarily illustrates an enlarged view of a portion marked A in FIG. 4A. In an embodiment, fastening attachments 109a and 109b are inserted through the through holes 107a and 107b of the mounting brackets 106a and 106b on the arms 101 and 102 respectively, of the saddlebag support apparatus 100 to fasten the saddlebag support apparatus 100 to the rear section 301a of the vehicle 301. The fastening attachments 109a and 109b comprise, for example, about 8 millimeters (mm)×1.25 mm bolts 110a and 110b respectively, with a length of about 80 mm to about 90 mm, and washers 111a and 111b respectively as exemplarily illustrated in FIG. 4B. A user can remove the original equipment manufacturer (OEM) bolts positioned, for example, on the rear section 301a of the vehicle 301 to fix the fastening attachments 109a and 109b that are configured for the saddlebag support apparatus 100. The saddlebag support apparatus 100 can be attached to the rear section 301a of the vehicle 301 in the presence or absence of original equipment manufacturer (OEM) fenders. The mounting brackets 106a and 106b on the arms 101 and 102 of the saddlebag support apparatus 100 respectively, can be bolted to a rear passenger handle 301b on the rear section 301a of the vehicle 301 by replacing the original fasteners with longer bolts 110a and 110b and washers 111a and 111b respectively. This allows the rear passenger handle 301b to remain functional and operate with or without a rear fender and/or mufflers installed. A rear passenger handle 301b is an attachment typically positioned on the rear section 301a of the vehicle 301, for example, a motorcycle, and that can be held by a passenger for support while the passenger sits on a passenger side of the vehicle 301, behind a rider of the vehicle 301.

[0027] A user can attach a flexible saddlebag 201 exemplarily illustrated in FIGS. 2A-2C, to the vehicle 301, for example, a sports bike using the saddlebag support apparatus 100. For purposes of illustration, the detailed description refers to the use of the saddlebag support apparatus 100 with respect to sports bikes and motorcycles; however the scope of the saddlebag support apparatus 100 disclosed herein is not limited to usage with sports bikes and motorcycles, but may be extended to be used in multiple different two wheeled vehicles.

[0028] FIG. 5 exemplarily illustrates an enlarged view of the saddlebag support apparatus 100, showing a saddlebag 201 secured to the saddlebag support apparatus 100. The attachment element 202 of the saddlebag 201 can be attached to any one of the connector elements 108a, 108b, and 108c of

the saddlebag support apparatus 100. For example, a strap 202a of the saddlebag 201 is inserted into the opening 108f of the connector element 108c, and fastened using the fastener 202b as exemplarily illustrated in FIG. 5, to secure the saddlebag 201 to the saddlebag support apparatus 100. In an embodiment, another strap 203 of the saddlebag 201 is wound around the arm 101 of the saddlebag support apparatus 100 as exemplarily illustrated in FIG. 5, prior to attaching the saddlebag support apparatus 100 to the rear section 301a of the vehicle 301 using the fastening attachments 109a and 109b.

[0029] FIG. 6A exemplarily illustrates a left side perspective view of a vehicle 301, showing a pair of saddlebag support apparatuses 100a and 100b attached to a rear section 301a of the vehicle 301 and saddlebags 201 secured to the saddlebag support apparatuses 100a and 100b. In an embodiment, a kit comprising one or a set of saddlebag support apparatuses 100a and 100b and one or a set of saddlebags 201 is provided. The saddlebags 201 are detachably attached to the saddlebag support apparatuses 100a and 100b for carrying items on the vehicle 301. Each of the saddlebag support apparatuses 100a and 100b comprises at least two arms 101 and 102, a support frame 103, and one or more connector elements 108a, 108b, and 108c as disclosed in the detailed description of FIGS. 1A-1F. In an embodiment, the kit further comprises fastening attachments 109a and 109b for fastening the saddlebag support apparatuses 100a and 100b to the rear section 301a of the vehicle 301 via the through holes 107a and 107b of the mounting brackets 106a and 106b respectively, of the saddlebag support apparatuses 100a and 100b. The saddlebags 201 are removably attached to the saddlebag support apparatuses 100a and 100b positioned on the rear section 301a of the vehicle 301. Each of the saddlebags 201 comprises attachment elements 202 configured to be inserted into any one or more of the openings 108d, 108e, and 108f of the connector elements 108a, 108b, and 108c respectively, of each of the saddlebag support apparatuses 100a and 100b. The attachment elements 202 of each saddlebag 201 are secured to the support frame 103 of each of the saddlebag support apparatuses 100a and 100b.

[0030] FIG. 6B exemplarily illustrates a rear elevation view of a vehicle 301, showing a pair of saddlebag support apparatuses 100a and 100b attached to a rear section 301a of the vehicle 301 and saddlebags 201 secured to the saddlebag support apparatuses 100a and 100b. Each saddlebag 201 is removably attached to the support frame 103 of each of the saddlebag support apparatuses 100a and 100b using the attachment elements 202 through the connector elements 108a and 108c as exemplarily illustrated in FIGS. 6A-6B. The connector elements 108a, 108b, and 108c of the saddlebag support apparatuses 100a and 100b allow the saddlebags 201 to be secured within the receptacle 104 of the support frame 103 using one or more attachment elements 202 of the saddlebags 201. The saddlebag support apparatuses 100a and 100b accommodate saddlebags 201 of a larger size than the size of the support frames 103 of the saddlebag support apparatuses 100a and 100b. The straps 202a of the saddlebags 201 pass through one or more of the connector elements 108a, 108b, and 108c on the support frames 103 of the saddlebag support apparatuses 100a and 100b. In an embodiment, an attachment element 202 of a saddlebag 201 is directly wound through the receptacle 104 defined by the support frame 103 and fastened around the support frame 103 as disclosed in the provisional patent application No. 62/069,818 titled "Saddlebag Support Apparatus", filed in the United States Patent and

Trademark Office on Oct. 28, 2014. The saddlebags **201** hang onto the sides of the vehicle **301**, for example, the motorcycle without affecting operation of components, for example, the rear fender, mufflers, passenger handles, etc., of the motorcycle. One or more saddlebags **201** of different sizes can be attached to the motorcycle using the saddlebag support apparatuses **100a** and **100b**.

[0031] The support frame **103** of the saddlebag support apparatus **100** exemplarily illustrated in FIGS. 1A-1F, is made of tube steel that is bent or stamped according to a pattern or a die. When a large scale production of the saddlebag support apparatus **100** is required, suitable jigs and other assembly aids are needed to speed the production rate and consistency of the saddlebag support apparatus **100**. After the saddlebag support apparatus **100** is manufactured, a protective finish, for example, paint or plating is applied to the saddlebag support apparatus **100** to prevent corrosion. The cost involved in the manufacture of the saddlebag support apparatus **100** is low due to the relatively low material costs and labor costs involved. A semi-skilled worker can be employed for manufacturing the saddlebag support apparatus **100**. The manufacturing process of the saddlebag support apparatus **100** comprises, for example, steel stamping and forming methods, welding methods, coating methods, mechanical device assembly methods, and associated mass production assembly technologies.

[0032] The foregoing examples have been provided merely for the purpose of explanation and are in no way to be construed as limiting of the saddlebag support apparatus **100** disclosed herein. While the saddlebag support apparatus **100** has been described with reference to various embodiments, it is understood that the words, which have been used herein, are words of description and illustration, rather than words of limitation. Further, although the saddlebag support apparatus **100** has been described herein with reference to particular means, materials, and embodiments, the saddlebag support apparatus **100** is not intended to be limited to the particulars disclosed herein; rather, the saddlebag support apparatus **100** extends to all functionally equivalent structures, methods and uses, such as are within the scope of the appended claims. Those skilled in the art, having the benefit of the teachings of this specification, may effect numerous modifications thereto and changes may be made without departing from the scope and spirit of the saddlebag support apparatus **100** disclosed herein in its aspect.

I claim:

1. A saddlebag support apparatus comprising:
  - at least two arms removably connected to a rear section of a vehicle; and
  - a support frame with a geometric shape extending from lower ends of said at least two arms, said support frame defining a receptacle configured to receive one or more attachment elements of a saddlebag to secure said saddlebag to said support frame.
2. The saddlebag support apparatus of claim 1, further comprising an interconnecting member positioned and connected between said at least two arms and substantially perpendicular to each of said at least two arms, wherein said interconnecting member is configured to preclude deflection of said support frame when said saddlebag is mounted onto said support frame, thereby providing rigidity to said support frame.
3. The saddlebag support apparatus of claim 1, further comprising one or more connector elements positioned at

predetermined locations on an inner plane of said support frame, wherein each of said one or more connector elements comprises an opening configured to receive and accommodate said one or more attachment elements of said saddlebag to secure said saddlebag to said support frame.

4. The saddlebag support apparatus of claim 1, wherein one of said at least two arms is substantially longer than another one of said at least two arms.

5. The saddlebag support apparatus of claim 1, further comprising mounting brackets rigidly attached to upper ends of said at least two arms, wherein said mounting brackets comprise through holes for receiving fastening attachments that fasten said saddlebag support apparatus to said rear section of said vehicle.

6. A saddlebag support apparatus comprising:

at least two arms removably connected to a rear section of a vehicle;

a support frame with a geometric shape extending from lower ends of said at least two arms, said support frame defining a receptacle configured to receive one or more attachment elements of a saddlebag to secure said saddlebag to said support frame; and

one or more connector elements positioned at predetermined locations on an inner plane of said support frame, wherein each of said one or more connector elements comprises an opening configured to receive and accommodate said one or more attachment elements of said saddlebag to secure said saddlebag to said support frame.

7. The saddlebag support apparatus of claim 6, further comprising an interconnecting member positioned and connected between said at least two arms and substantially perpendicular to each of said at least two arms, wherein said interconnecting member is configured to preclude deflection of said support frame when said saddlebag is mounted onto said support frame, thereby providing rigidity to said support frame.

8. The saddlebag support apparatus of claim 6, wherein one of said at least two arms is substantially longer than another one of said at least two arms.

9. The saddlebag support apparatus of claim 6, further comprising mounting brackets rigidly attached to upper ends of said at least two arms, wherein said mounting brackets comprise through holes for receiving fastening attachments that fasten said saddlebag support apparatus to said rear section of said vehicle.

10. A kit comprising:

a saddlebag support apparatus comprising:

at least two arms removably connected to a rear section of said vehicle;

a support frame with a geometric shape extending from lower ends of said at least two arms, said support frame defining a receptacle configured to receive one or more attachment elements of a saddlebag to secure said saddlebag to said support frame; and

one or more connector elements positioned at predetermined locations on an inner plane of said support frame, wherein said one or more connector elements comprise openings configured to receive and accommodate said one or more attachment elements of said saddlebag to secure said saddlebag to said support frame; and

said saddlebag detachably attached to said saddlebag support apparatus for carrying said items, wherein said

saddlebag comprises said one or more attachment elements configured to be inserted into said openings of said one or more connector elements of said saddlebag support apparatus and secured to said support frame of said saddlebag support apparatus.

**11.** The kit of claim **10**, wherein said saddlebag support apparatus further comprises an interconnecting member positioned and connected between said at least two arms of said saddlebag support apparatus and substantially perpendicular to each of said at least two arms, wherein said interconnecting member is configured to preclude deflection of said support frame of said saddlebag support apparatus when said saddlebag is mounted onto said support frame, thereby providing rigidity to said support frame.

**12.** The kit of claim **10**, wherein one of said at least two arms of said saddlebag support apparatus is substantially longer than another one of said at least two arms.

**13.** The kit of claim **10**, wherein said saddlebag support apparatus further comprises mounting brackets comprising through holes, wherein said mounting brackets are rigidly attached to upper ends of said at least two arms of said saddlebag support apparatus.

**14.** The kit of claim **13**, further comprising fastening attachments for fastening said saddlebag support apparatus to said rear section of said vehicle via said through holes of said mounting brackets of said saddlebag support apparatus.

\* \* \* \* \*